

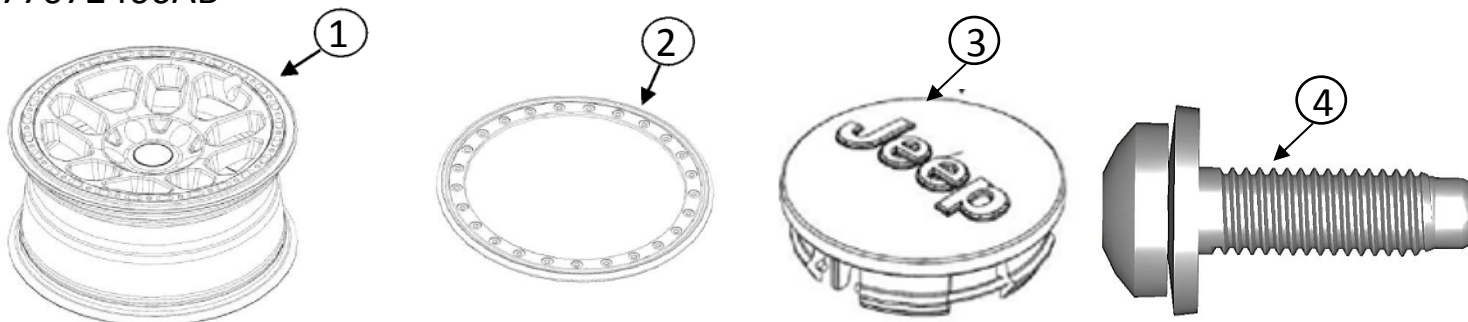

# Bead Lock Capable Wheel

www.mopar.com

77072466AB



Call Out	Jeep Wrangler	Quantity	Service Part (Y/N)	Part Number
1	Mopar Bead Lock Capable Wheel	1	Y	68361859AB
2	Trim Ring	1	Y	68362086AA
3	Jeep Center Cap	1	Y	1LB77RXFAC
4	Trim Ring Hardware	25	Y	06511068AA

82215593

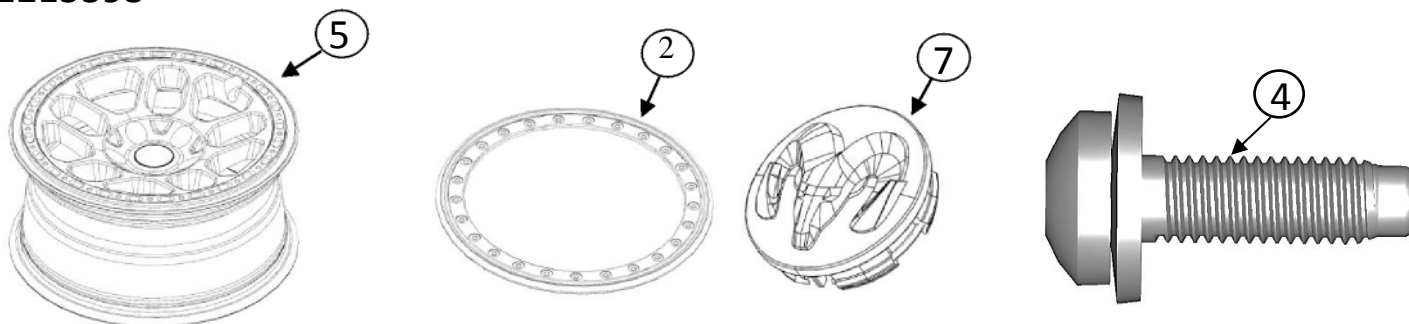

Call Out	Ram 1500	Quantity	Service Part (Y/N)	Part Number
5	Mopar Bead Lock Capable Wheel	1	Y	68361860AA
2	Trim Ring	1	Y	68362086AA
7	Ram Center Cap	1	Y	1LB72RXFAB
4	Trim Ring Hardware	25	Y	06511068AA

**READ, UNDERSTAND, AND FOLLOW ALL INSTRUCTIONS CAREFULLY BEFORE INSTALLATION!!!**

**Note: Optional functional Bead Lock Ring Kit, part number P5160154 sold separately.**

## Bead Lock Capable Wheel Mounting

### ON ROAD USE

1. Remove Trim Ring (2) and fasteners (4) from wheel.
2. Mount tire as normal, using a tire machine.

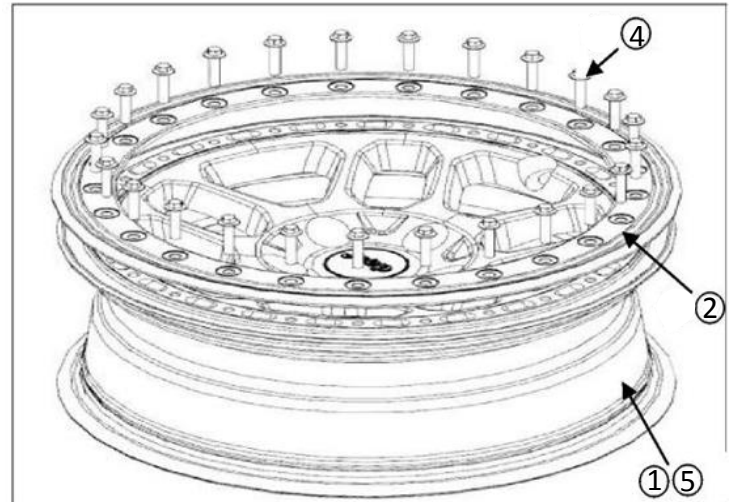

3. Position ring (2) on wheel, aligning bolt holes. Hand thread bolts.

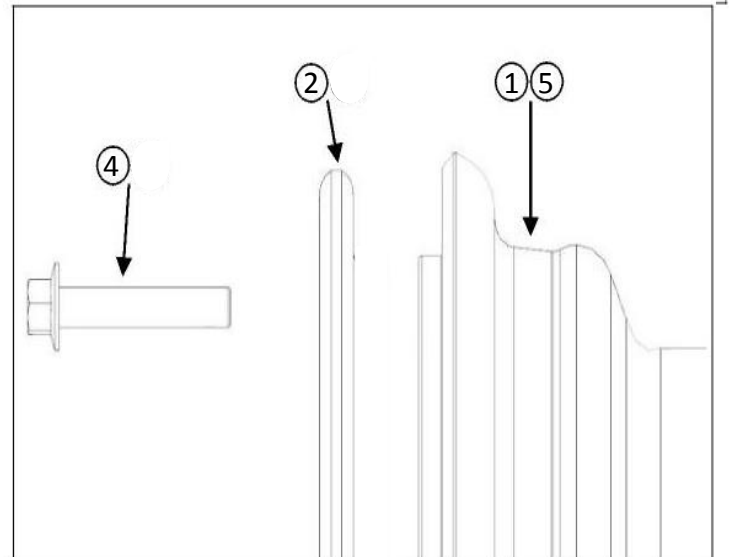

4. Hand-tighten the bolts in the following sequence, ensuring uniform gap between the ring and wheel surface.
5. Making sure there is no gap between the wheel surface and ring, torque bolts to 27 N-m (20 lb.-ft.) in the same sequence.
6. Inflate tire to recommended pressure.
7. Balance wheel/tire/ring assembly.
8. Mount tire/wheel/ring assembly to vehicle.
9. Install Center Cap (3) or (7).
10. Fold and place instruction sheet in the vehicle's glove box.

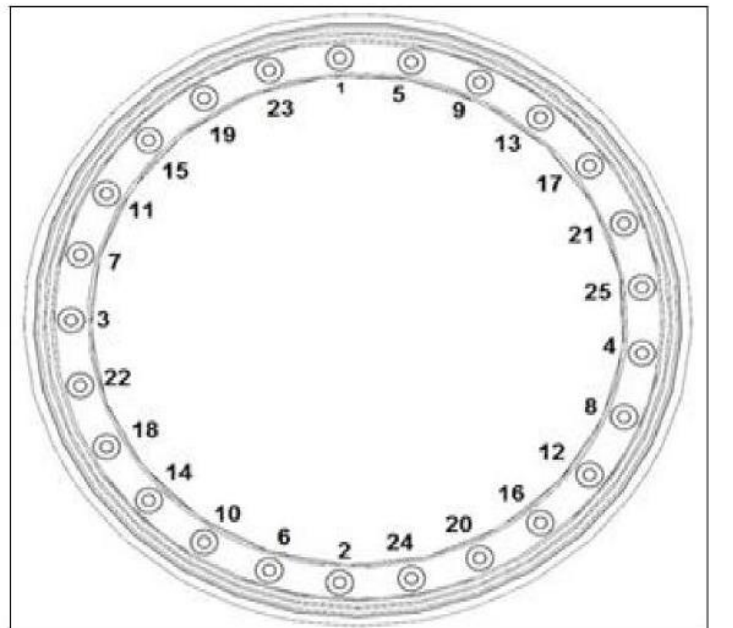



# Cerradura de Cuenta Rueda Capaz

www.mopar.com

77072466AB

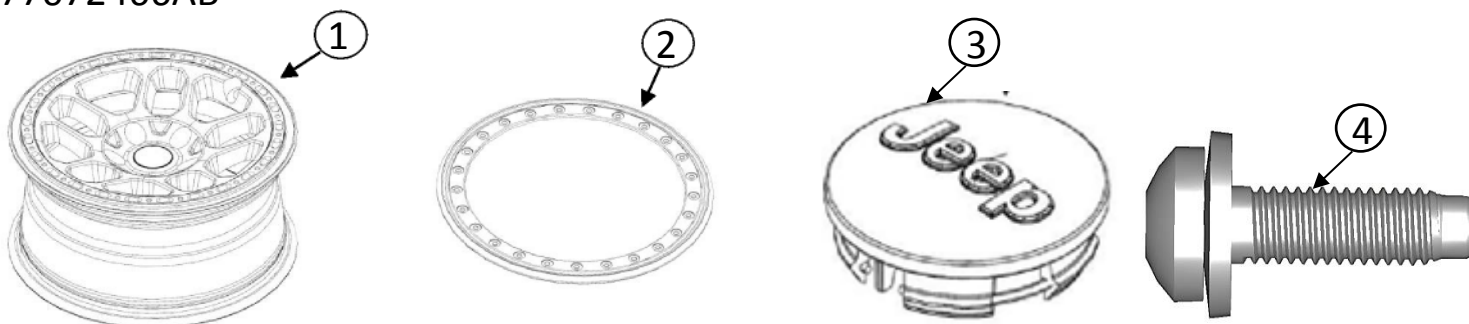

la llamada	Jeep Wrangler	Cantidad	Parte de Servicio (S/N)	Numero de Pieza
1	Mopar Cerradura de Cuenta Rueda Capaz	1	Y	68361859AB
2	Toque Neto	1	Y	68362086AA
3	Jeep Gorro de Centro	1	Y	1LB77RXFAC
4	Hardware Neto De toque	25	Y	06511068AA

82215593

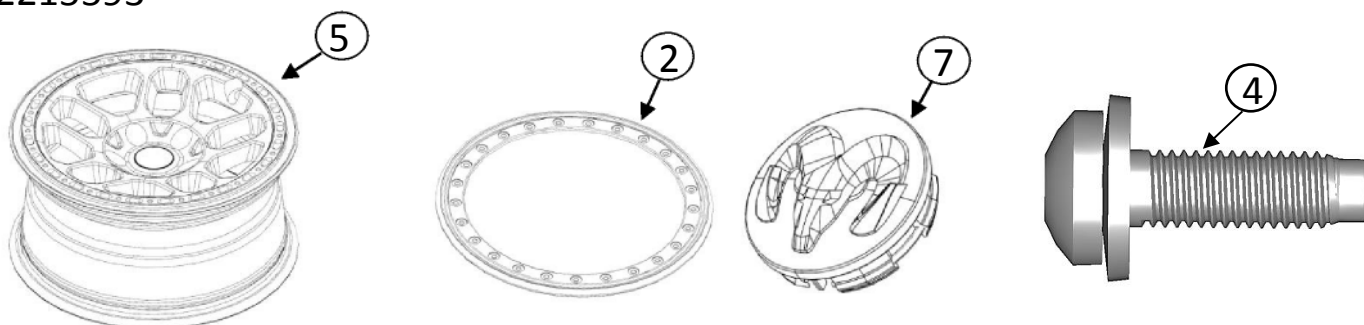

la llamada	Ram 1500	Cantidad	Parte de Servicio (S/N)	Numero de Pieza
5	Mopar Cerradura de Cuenta Rueda Capaz	1	Y	68361860AA
2	Toque Neto	1	Y	68362086AA
7	Ram Gorro de Centro	1	Y	1LB72RXFAB
4	Hardware Neto De toque	25	Y	06511068AA

**¡LEA, ENTIENDA, Y SIGA TODAS LAS INSTRUCCIONES CON CUIDADO ANTES DE INSTALACIÓN!**

## Nota:

Juego opcional de anillos de cierre de perlas, número de pieza P5160154 vendido por separado.

## Cerradura de Cuenta Montaje de Rueda Capaz

### SOBRE EMPLEO DEL CAMINO

1. Quitar el Toque Neto (2) y sujetadores (4) de la rueda.
2. Neumático de montaje como normal, usando una máquina de neumático.

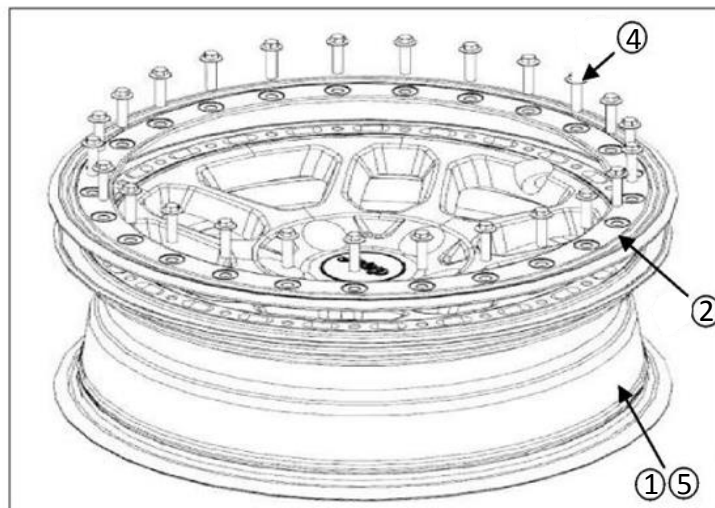

3. Toque de posición (2) sobre rueda, alineando agujeros de cerrojo. Cerrojos de hilo de la mano.

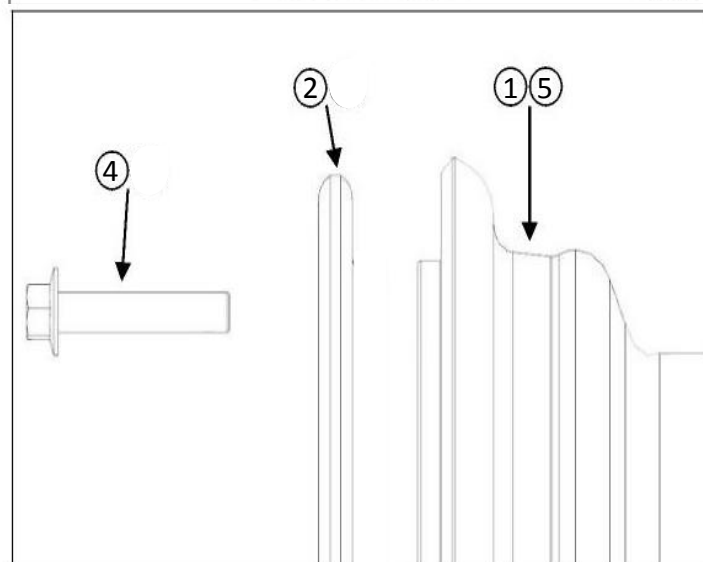

4. Apriete mano los cerrojos en la secuencia siguiente, asegurando el hueco uniforme entre la superficie de rueda y el toque.
5. El asegurando de no hay ningún hueco entre la superficie de rueda y el toque, cerrojos de momento de rotación a 27 N-m (20 lb.-ft.) en la misma secuencia.
6. Infle el neumático a la presión recomendada.
7. Asamblea de rueda/neumático/toque de equilibrio
8. Asamblea de neumático/rueda/toque de montaje a vehículo.
9. Instale el Gorro de Centro (3) o (7).
10. Pliegue y hoja de instrucción de lugar en la guantera del vehículo.

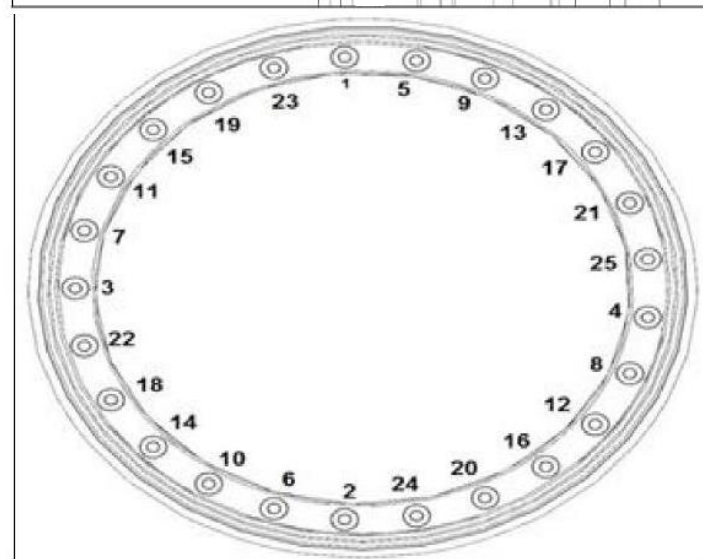



# Serrure de Perle Roue Capable

77072466AB

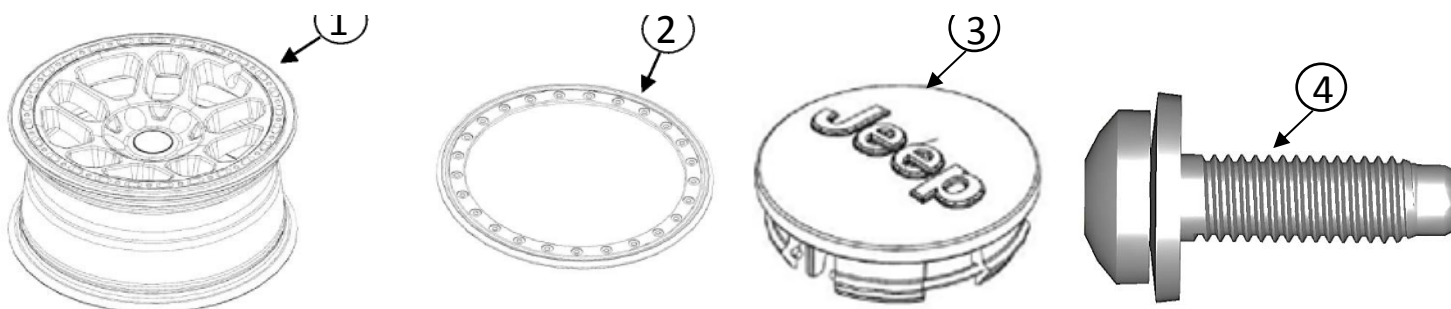

Appel de Note	Jeep Wrangler	Quantite	Pièce de rechange (O/N)	Numero de Piece
1	Mopar Serrure de Perle Roue Capable	1	Y	68361859AB
2	Enjoliveur	1	Y	68362086AA
3	Jeep Capuchon Central	1	Y	1LB77RXFAC
4	Enjoliveur Hardware	25	Y	06511068AA

82215593

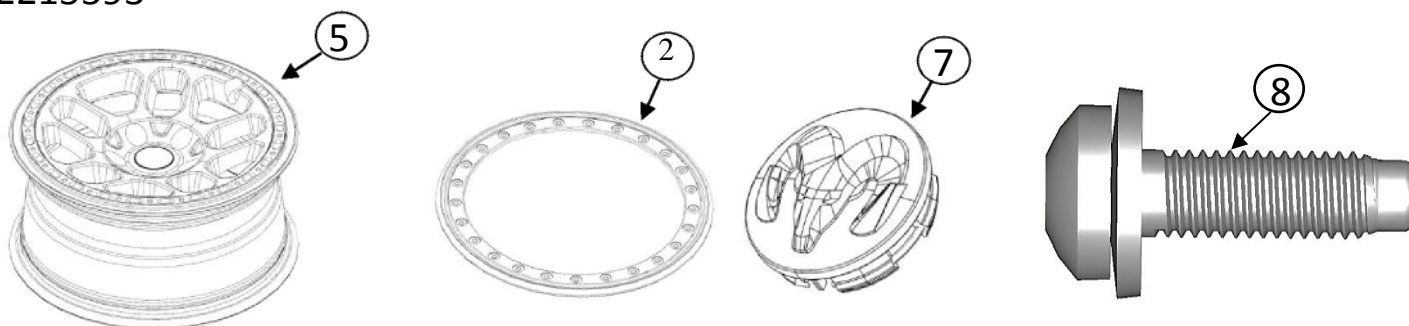

Appel de Note	Ram 1500	Quantite	Pièce de rechange (O/N)	Numero de Piece
5	Mopar Serrure de Perle Roue Capable	1	Y	68361860AA
2	Enjoliveur	1	Y	68362086AA
7	Ram Center Cap	1	Y	1LB72RXFAB
4	Enjoliveur Hardware	25	Y	06511068AA

**LISEZ, COMPRENEZ ET SUIVEZ TOUTES LES INSTRUCTIONS SOIGNEUSEMENT AVANT L'INSTALLATION!**

Remarque: Kit de bague de serrage optionnel en option, référence P5160154 vendu séparément.



## Serrure de Perle Montage de Roue Capable SUR UTILISATION DE ROUTE

1. Enlevez l'Anneau Net (2) et des attaches (4) de la roue.
2. Pneu de mont comme normal, utilisant une machine de pneu.

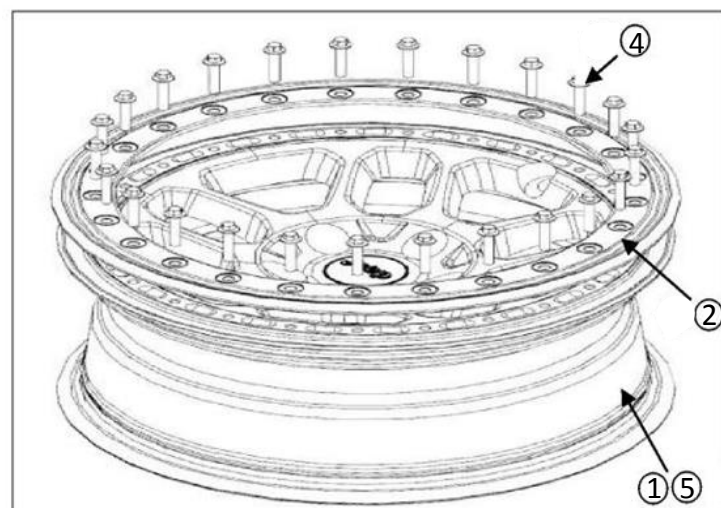

3. Anneau de position (2) sur roue, alignant refuges. Boulons de fil manuels.

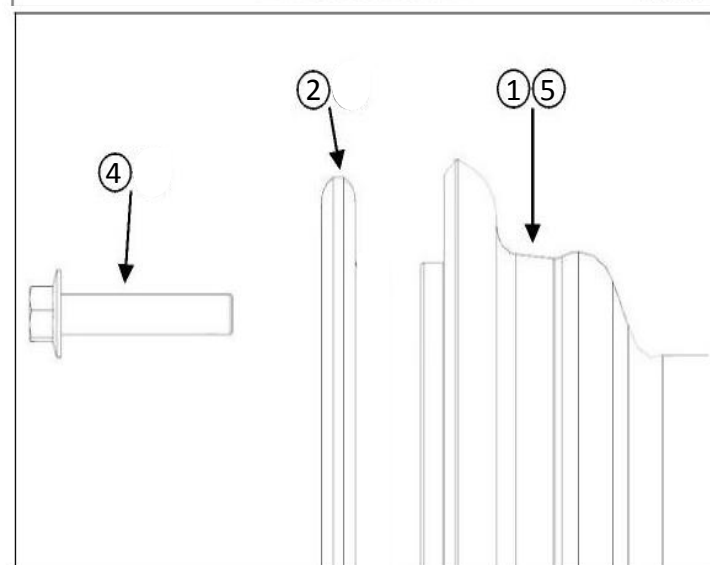

4. Serrez main les boulons dans l'ordre suivant, assurant l'écart uniforme entre la surface de roue et l'anneau.
5. L'assurant n'est là aucun écart entre la surface de roue et l'anneau, des boulons de moment de torsion à 27 N-m (20 Lb.-ft.) dans le même ordre.
6. Gonflez le pneu à la pression recommandée.
7. Roue d'équilibre/pneu/assemblée d'anneau.
8. Assemblée de pneu/roue/anneau de mont à véhicule.
9. Installez la Casquette de Centre (3) ou (7).
10. Pli et feuille d'instruction d'endroit dans la boîte à gants du véhicule.

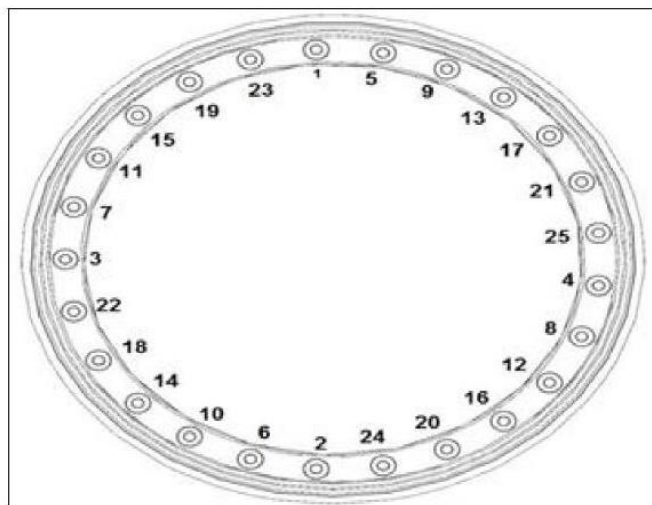

# DOCUMENT HISTORY

Date	Section	Summary of Changes Made	Notes
22 Nov 2016		Initial Release	
27 July 2017		Black Primer and machining for 14 mm Studs	